

harman/kardon

Rabco ST-5

Owner's Manual



The ST5 is an expression of our love for music and our desire to hear music reproduced as accurately as possible.

We believe you will find using the ST5 turntable as satisfying an experience as we enjoyed in designing and building it.

The ST5 tracks records precisely as the original masters are cut: in perfect tangency for minimum distortion. Straight-line tracking completely eliminates the problems of tracking error and stylus overhang. Anti-skating correction is unnecessary because the system exerts no skating force. External forces acting on the stylus are in complete balance. Further, the tangential arm is much lighter than conventional arms, since it is much shorter. For these reasons, the ST5 transcribes records with unprecedented clarity.

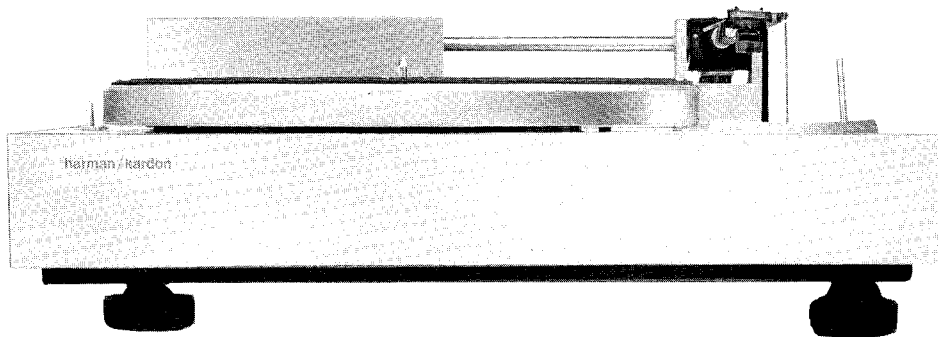

The precision of the tangential arm is complemented by other special features:

Pneumatically damped cueing descent.

Level indicator and adjustable feet for precise leveling.

Warning: To prevent fire or shock hazard, do not expose this turntable to rain or moisture.

Operating the Turntable

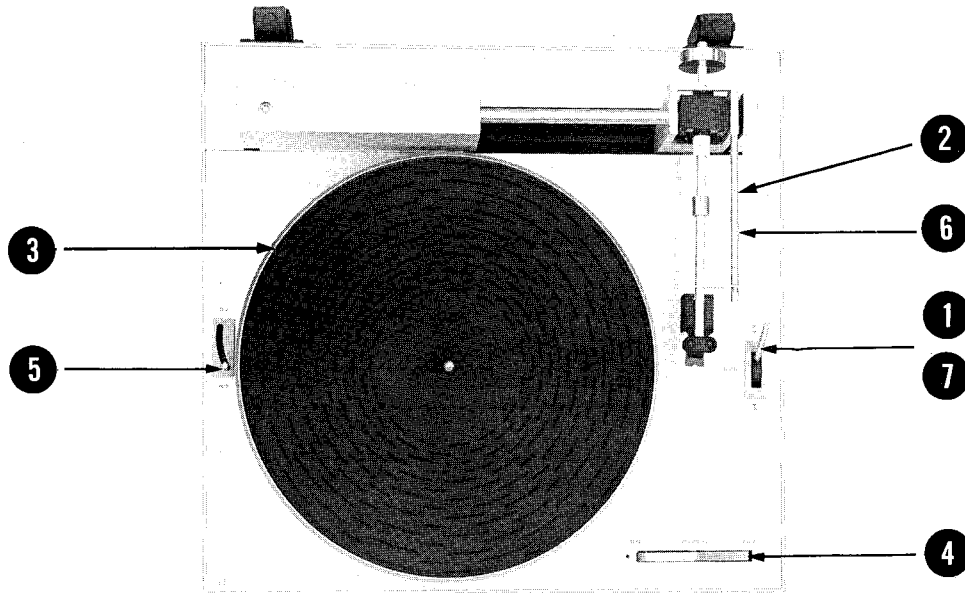

1. Cue lever rear.

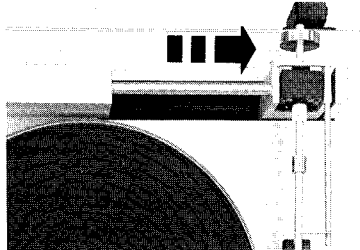

2. Move carriage to extreme right, using Control Arm.



3. Place record on platter.

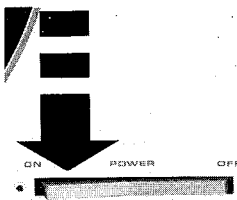

4. Depress (left side) power switch

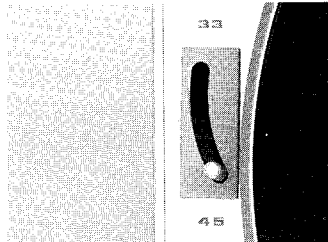

5. Set speed control to 33-1.3 or 45 rpm with platter in motion.

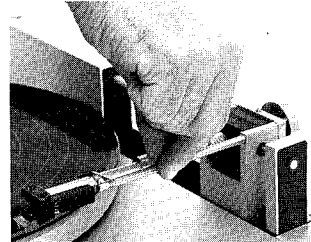

6. Using control arm, position carriage so stylus will be lowered onto the lead-in groove.

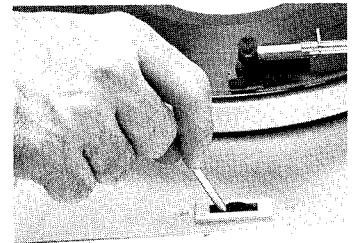

7. Move cue lever forward. Stylus will be gently lowered onto the record.

8. You can select another portion of the record at any time:
 - a. Move cue to rear.
 - b. Using control arm, position stylus over desired part of record.
 - c. Move cue lever toward you, arm will descend.
9. You can stop the record at any time:
 - a. Move cue lever to rear.
 - b. Using control arm, move carriage to extreme right.
 - c. Depress power switch.
10. When record is finished, arm will lift automatically and platter will stop.
11. **To change speed, the platter must be in motion.**

Additional tonearms complete with mounting hardware, Harman Kardon model number CH-5W, are available through your Harman Kardon dealer. With additional tonearms, you can use more than one cartridge without having to remount for each change.

Adjusting Arm Length

The stylus will track in perfect tangency to the record groove when the arm length is properly adjusted. Loosen the mounting plate screw on the underside of the tonearm. Dress the signal wires forward and place the cartridge gauge on the arm as shown. The notch of the gauge fits over the black "T" bar, while the locating pin of the gauge fits in the corresponding hole in the arm.

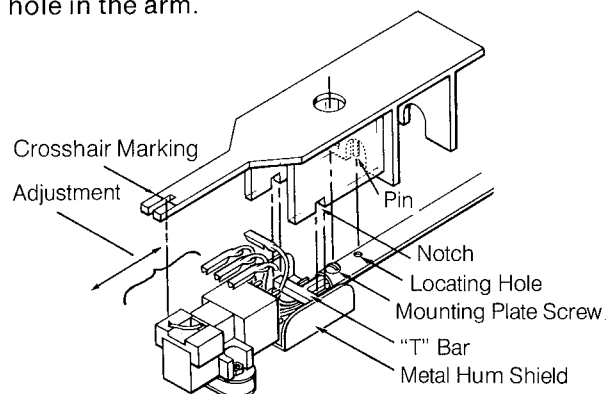

Note: Gauge fits "inside" walls of hum shield.

The cartridge assembly and mounting plate can be moved back and forth if the mounting plate screws and hex nuts are loose enough. Move the assembly so that the stylus lines up with the crosshair marking on the top of the cartridge gauge. Then tighten the mounting plate screw (access is provided through the large hole in the cartridge gauge) and the two cartridge mounting screws to lock your adjustment. Check that the cartridge has not twisted and that the stylus is visually in line with the center of the tonearm tube.

Connecting the Signal Wires

Connect the signal wires of the tonearm to the appropriate terminals on your cartridge. Use extreme care as the wires are delicate. Using tweezers or long-nose pliers will make connection easier.

The signal wires are color coded:

	Left	Right
	Channel	Channel
Signal	WHITE	RED
Ground	BLACK	GREEN

The cartridge may have a different color code or other marking system to identify its terminals. Consult the instructions supplied with your cartridge for this information.

When you have connected the signal wires, the tonearm will be ready to mount in the carriage.

Installing Leveling Feet

Remove the four (knurled) leveling feet from the upper foam packing and install on the male threaded adapters attached to the isolators. Leveling instructions are discussed in the following paragraphs.

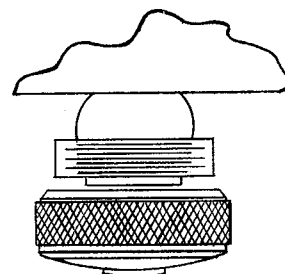

The Tonearm

Mounting the Tonearm

Move the cue lever to the rear. Using the control arm, move the cartridge to the right end of its travel. Now move the cue lever forward.

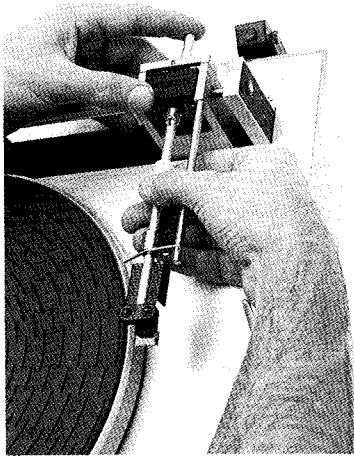

Note: If the cue lever cannot easily be moved fully forward, the lift gears have become engaged in shipment. To correct this condition:

1. Connect the power line cord of the ST5 to an AC outlet.
2. Turn the power switch on.
3. Allow the unit to run for about 20 seconds.
4. The turntable will shut off.

Move the slide-weight and mounting collar toward the cartridge end of the tonearm to expose the black connector. Note the key rib on the connector. Hold the arm with the key rib up. With the other hand, hold the counterweight shaft firmly and press down on the carriage nameplate to prevent the vertical bearing from twisting during installation of the tonearm. Introduce the tonearm UNDER its restrictor. Gently push the arm all the way into its keyed socket. Secure the tonearm by screwing in the locking collar; gently hand tighten only. If the cartridge is slightly twisted by normal tightening of the locking collar, loosen the collar and straighten the cartridge. Then hold the cartridge vertically straight while you re-tighten the locking collar.

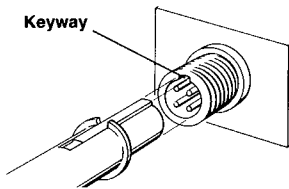

Balancing the Tonearm

Move the cue lever to the rear. The tonearm will rise into the restrictor notch.

Slip the counterweight onto the back of the counterweight shaft. If you encounter difficulty, lubricate the shaft with a drop of water. Move the cue lever forward and move the slide-weight back so that its front surface lines up with the rear-most graduation on the tonearm (0 grams).

Adjust the position of the counterweight so that the tonearm is balanced in the middle of its vertical travel. Push or pull the counterweight with a rotating motion for precise positioning. If the arm rises into the restrictor notch, pull the counterweight toward the front of the turntable. If the arm falls, push the counterweight toward the back of the turntable.

Note: If the tonearm falls, even with the counterweight back as far as it will go, your cartridge weighs over 10 grams, and requires a heavier counterweight. This weight, Harman Kardon model 15G, is available through your Harman Kardon dealer.

Setting the Tracking Force

Now that your tonearm is balanced, position the front surface of the slide-weight at the graduation corresponding to the vertical tracking force specified by the manufacturer of your cartridge.

The tracking force must be at least .75 gram for correct tripping, however, it is possible for the unit to track at lesser forces.

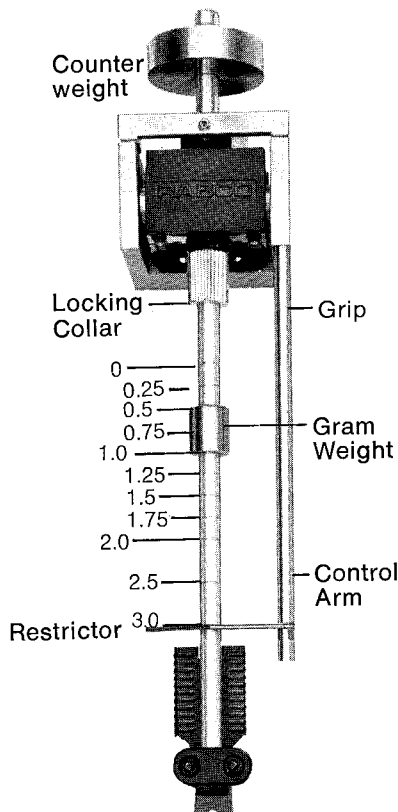

Example: 1 gram tracking force shown

Setting Up the Turntable

Installing the Dust Cover

Hold the dust cover tilted as if open and fit the dust cover's brackets onto the turntable's hinges, as shown.

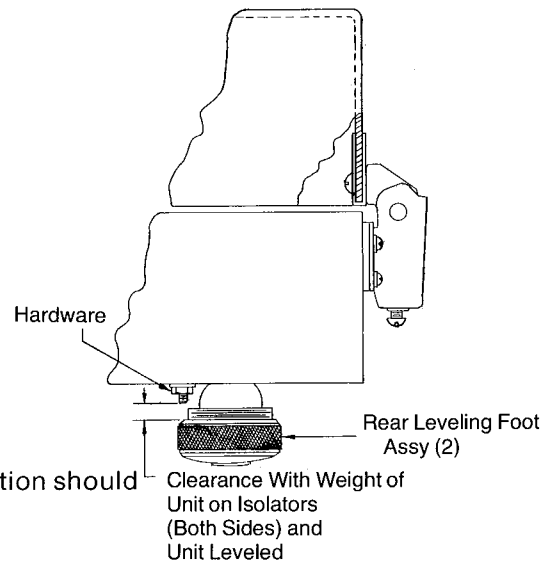
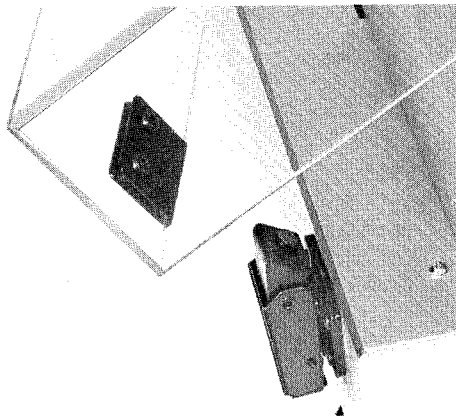

Positioning the Turntable

The ST5 should be placed on a firm, level surface. The location should be clean, and as vibration-free as possible.

Leveling

A level indicator is located on the left-rear corner of the turntable. When the bubble is perfectly centered in the red circle, the turntable is level. Adjust the feet of the ST5 to level the turntable, starting with all four feet in their highest position.

For example, if the bubble rests towards the right-front side of the red circle, you would lower the right-front corner of the turntable. To lower a corner, turn the foot counterclockwise, as seen from above. Make certain the rear feet are not turned up so far as to contact hardware on the base. Not doing so can result in improper isolation. Recheck balancing and tracking force of tonearm after turntable has been leveled in its final location.

Output Connections

Make sure that your amplifier is switched off. Connect the turntable's two output plugs and ground spade lug to your amplifier. The left channel output plug is black, the right channel plug is red. Connect these to your amplifier's PHONO inputs. Connect the ground spade lug to chassis ground terminal on your amplifier (commonly marked GND) or an unpainted chassis screw (if required to reduce hum level).

You may need to separate the three cables so that they reach the receptacles on your amplifier. Move the plastic strain relief band down and gently pull the cables apart, if necessary, by pulling on the cable, never the plugs or spade lug.

Power Connection

Connect the power line cord of the ST5 to an AC outlet. If you connect the cord to an AC convenience outlet on the back of your amplifier, you may prefer a SWITCHED outlet. With a SWITCHED outlet, the turntable's power switch will be controlled by the amplifier's power switch.

Unpacking

Retain the packaging materials that accompany your ST5 so that the turntable may be shipped safely, should the need arise. After you take the ST5 out of the carton, remove the 3 cardboard shims (1) protruding from under the platter. Then remove the packing shim (2) and plastic tie (3) that secure the carriage. Move the cue lever (4) to the rear when you have removed the shim. Finally, remove the foam filler (5) from under the carriage opening.

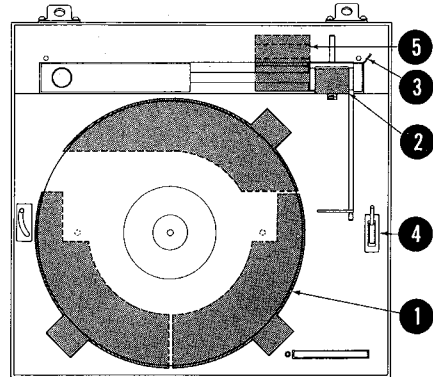
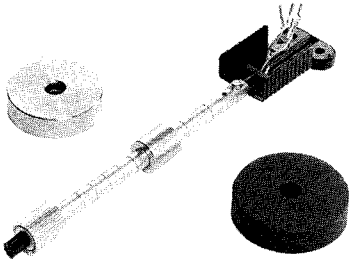

The Cartridge

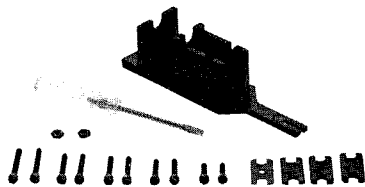

Selecting Shims

The ST5 tonearm normally accepts cartridges that weigh 10 grams or less. (Cartridges that weigh between 10 and 15 grams may be used on the ST5 with a special counterweight. This weight, Harman Kardon model 15G, is available through your Harman Kardon dealer.) Because cartridges differ in height, a set of four spacers (shims) of different thicknesses and a cartridge gauge have been provided to assure that the cartridge will track at the proper vertical angle.

Carefully place the cartridge (stylus up) and the cartridge gauge on a flat, smooth surface, as shown. Slide cartridge under gauge. If the stylus does not fit easily under the reference tab of the gauge, no shims are required. However, in most cases there will be a space between the top of the stylus and the lower surface of the reference tab. Select the shim(s) to fill this space.

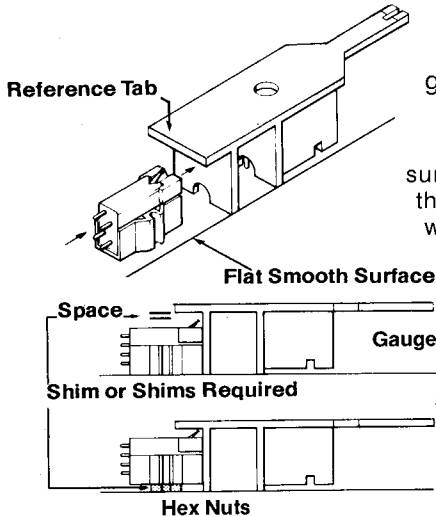

Note: If cartridge requires shim(s), failure to use shim(s) may result in improper tracking.

Mounting the Cartridge

Install the cartridge with the hex nuts, mounting screws, and necessary shims as shown. Five pairs of cartridge mounting screws of different lengths are supplied with the ST5. Use the shortest mounting screws that will hold the cartridge.

Install the hex nuts. They should be snug at this point, but only finger tight.

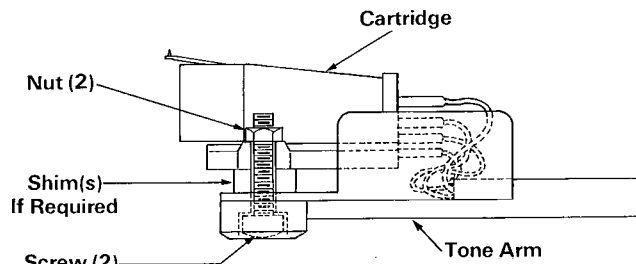
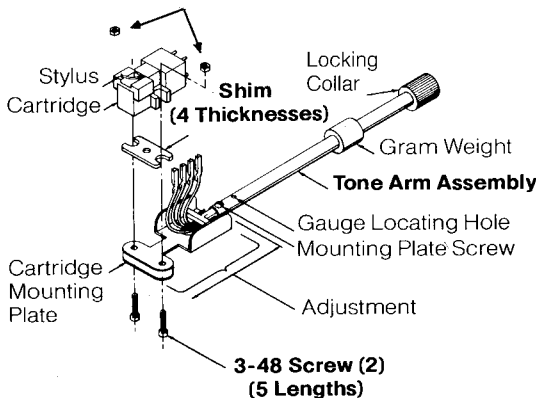

View of Cartridge Assembled on Arm

Adjustment and Maintenance

Tracking Adjustment

A tracking adjustment has been preset at the factory. However, some slippage may take place during shipment. You can ensure precise tangential tracking by following this procedure:

1. Make sure the tracking shaft is rotating (black cylinder, visible through opening in top plate). If it is not, rotate the platter one revolution in reverse direction, then try again.
2. Play a 33-1/3 rpm record.
3. Allow the arm to track across about one inch of the record.
4. Observe whether the arm is leading or lagging the notch in the restrictor arm. If the arm is lined up perfectly with the notch, and the arm cues straight up, no further adjustment is necessary. If not, refer to Step 5.
5. Move cue lever to rear. The tracking adjustment knob is located on the rear of the carriage. If the tonearm is leading the notch in the restrictor arm—tending toward the center of the record—turn the adjustment knob slightly clockwise as viewed from the rear. If the tonearm is lagging the notch—tending toward the beginning of the record—turn the knob slightly counterclockwise. Repeat the procedure until the tonearm remains closely lined up with the notch as it tracks across a complete record.

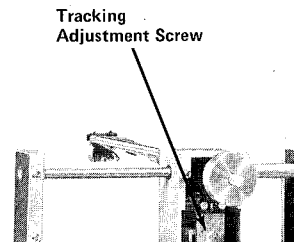

Cleaning the ST5

ST5 maintenance is limited to periodic cleaning and dusting. In particular, cleaning the slide rod and tracking shaft near the back of the turntable will help keep your ST5 in peak operating condition.

Move the cue lever to the rear. Using the control arm, move the carriage to the left end of its travel to expose the stainless steel slide rod. Clean the slide rod with a soft cloth or cotton swab moistened with isopropyl alcohol. Using the control arm, move the carriage to the right end of its travel.

The tracking shaft is the black cylinder visible through the carriage opening. (You can see the tracking shaft turn when the platter rotates.) Clean the tracking shaft as you did the slide rod. The stainless steel parts of the turntable (for example, the slide-weight and control arm) may be similarly cleaned.

Remove dust using the soft brush attachment of a canister-type vacuum cleaner rather than a dusting cloth or feather duster.

Clean the dust cover with a soft cloth and liquid glass cleaner. Never apply alcohol, solvents, or abrasives to the dust cover. Keep the dust cover closed when the ST5 is not in use to prevent dust from accumulating.

Ancillary items (available through your dealer).

HK Part #	Item
CH-5W	Tone Arm Assembly
15-G	Counterweight (for 10-15 gram cartridges.)

Specifications:

Tracking Force:	0°	Hum (Tone Arm In) DIN 45544:	-70 dB
Skating Force:	0	Speeds:	33-1/3, 45 RPM
Tone Arm Mass (Effective):	6 grams	Speed Constancy:	± 0.3%
Stylus Overhang:	0	Motor/Drive:	Synchronous AC with precision ground belt
Turntable Rumble DIN B:	-57 dB	Platter Weight:	2.4 lbs (1.1 Kg)
Wow and Flutter NAB weighted:	0.045%	Dimensions (incl. dust cover):	6-3/4" H x 16-1/2" W x 16-1/4" D 171mm H x 419mm W x 413mm D
DIN B:	0.12%	Weight Total:	20 lbs. (9.1 Kg)